



People Counting System

PCS-500A

DESCRIPTION

The PCS500 system is designed to monitor the flow of people into and out of buildings. Using microprocessor technology the system can monitor up to eight separate portals and differentiate between people entering and leaving a doorway. Three types of sensor heads are available, a single beam photoelectric, (PSH1), a dual beam photoelectric (PSH2) and a PIR, passive infrared (PSH3).

Normally the single beam and PIR are used in doorways with traffic flow in one direction and the dual beam with bi-directional traffic. The sensors are programmable and can be set to suit the installation. The PIR type is used where it is difficult to install a reflector and also for overhead use and can monitor up to a distance of 5 metres from the sensor.

With the ability to monitor multiple doorways this system can be used in installations with several doorways and can have different sensor types connected in one installation. The display unit is connected to the remote sensor heads using standard RJ45 type data cables and multiple sensors are simply "daisy chained" together to provide very simple installation of the system. The display unit communicates with the sensor heads and keeps a tally of the total of people entering the building over two periods (such as a daily and weekly total) and the current occupancy level. All totals can be independently reset.

Options are also available to log the traffic at each portal. Data outputs are provided to drive a remote display such as our BD100-5 large display, and to allow a computer to gather the data stored in the system.

Desk Top Display Unit



Desk Top Display Unit: PCS500A

The heart of the system, the PCS500A is powered from the AC line and provides power to and reads the data from the sensor heads. The unit has a 5 decade LED display which can be selected to show the three totals stored, (Total IN 1, Total IN 2 and Occupancy) and each total can be independently reset. These facilities enable an installation to show the total number of visitors over two time periods such as a daily total and a monthly total, as well as the current number of people in the building.

A data output socket is provided that can interface to another display in a remote location that can either show the same total as the local display or can independently show any of the totals. For example this could be used with an Abtek BD100-5 large display unit installed above the main entrance to show the total number of visitors to an exhibition. Several remote displays can be linked to the one base unit.

An optional data output is available to connect to a remote computer that can be used to collect the count totals and also for the computer to remotely reset any of the totals . This can be used to gather information for management audit.

Typical System

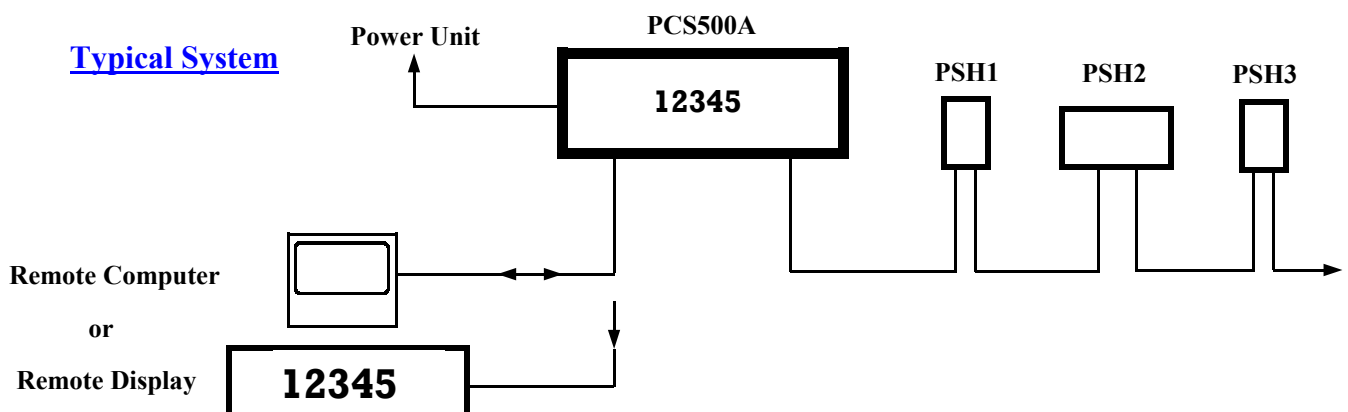



PCS-500A

Accuracy:

The accuracy of the PCS500A system depends on the details of each installation. The software in the sensor heads is designed to eliminate as many errors as possible due to such things as swinging arms but situations such as people walking side by side will cause errors. The control of traffic through the sensors is important for overall accuracy with people walking steadily through in single file with gaps between each person giving the best results.

The positioning of sensors is important, both in terms of the position in the flow, so that after a pay booth is better than before where people may bunch up in a queue, and height above the ground, so that set at hip height prevents double counting of legs but may miss small children. However proper installation will give good results in most applications.

The count totals are stored in the PCS500 in non-volatile memory when the power is switched off and restored to the display when next turned on. The memory will last at least 10 years without power.

User Controls

The PCS500 has two controls on the front panel. The RESET button is used to clear the count totals as required. The button only resets the total that is currently displayed. This facility enables the user to keep separate totals such as a daily total (reset the count every day) and a monthly total (reset at beginning of each month). The second control is the DISPLAY button. This is used to select the total being displayed and steps through the three totals each time it is pressed. The display selected at switch off is restored when the unit is switched back on.

A key operated switch is on the side of the unit which is used to disable the RESET button to prevent unauthorised operation.

Specification

Power Input:	12 VDC from 230 VAC plug in power unit supplied
Maximum Count:	99999 (others to order)
Display:	14 mm high red LED digits
Count Memory:	All count totals are stored indefinitely while power is turned off
Controls:	Reset: Resets to zero the selected total Display: Selects which total is shown Reset Lock Off: Key operated disables the reset button
Dimensions:	PCS500A 190 x 120 x 60 (rear) 32 (front) mm

Order Code

Display Unit:	PCS-500A
RJ45 Connecting Cable:	RJ45 + length Standard lengths available - 1, 2, 3, 5, 7, 10, 15, 20 metres

Options

Computer Interface	PCS-500A-C
Multi Zone Monitoring	PCS-500B (Specification to order)
Specials	Custom designed variations of the basic system

ABTEK CONTROLS A Servecon Ltd Company

Unit 16 Chamberlains Industrial Estate, Sporehams Lane, Danbury, Essex CM3 4AJ
Tel: 01245 222315 Fax: 01245 227072 Email sales@abtekcontrols.com

WEB www.abtekcontrols.com

Manufacturers and Distributors of Electronic Control Components and Systems

